



RFU-433 User Manual

433 MHz RS-232/RS-485 Wireless Modem

Jan. 2024, Version 1.12



Warranty

All products manufactured by ICP DAS are warranted against defective materials for a period of one year from the date of delivery to the original purchaser.

Warning

ICP DAS assumes no liability for damages consequent to the use of this product. ICP DAS reserves the right to change this manual at any time without notice. The information furnished by ICP DAS is believed to be accurate and reliable. However, no responsibility is assumed by ICP DAS for its use, nor for any infringements of patents or other rights of third parties resulting from its use.

Copyright

Copyright © 2017 by ICP DAS. All rights are reserved.

Trademarks

Names are used for identification purposes only and may be registered trademarks of their respective companies.

Contact Us

If you have any questions, please feel free to contact us via email at:

service@icpdas.com

Table of Contents

- 1. Introduction..... 4
 - 1.1 Features..... 5
 - 1.2 Specification 6
 - 1.3 Dimensions 8
 - 1.4 Appearance..... 9
- 2. Configuration 11
- 3. RFU-433 Utility 14
- 4. Application Example..... 17
- A. RSSI Data and Signal Strength Description..... 19

1. Introduction

The RFU-433 is an RS-232/RS-485 to 433 MHz radio modem that converts data from RS-232/RS-485 devices into 433 MHz wireless messages in the ISM band and transmitted then out using transparent mode.



The RFU-433 can reach up to 500 meters in a 9600 bps wireless baud rate and in a direct line-of-sight (LOS) environment. In order to overcome the interference that may be encountered in the environment, the RFU-433 provides a range of wireless baud rates from 57,600 bps to a minimum of 650 bps for the user to adjust. In addition, the user can adjust the wireless channel and group ID to avoid interference between two neighboring RFU-433 networks. The RFU-433 also supports repeater mode to solve the problem of communication distance or dead space. All these functions can be achieved through the dedicated software with simple settings, and because of the easy setup, it is also relatively simple to replace the RFU-433 device for system maintenance.

1.1 Features

- 433 MHz Radio Frequency
- 16 RF channels with 100 kHz channel spacing
- Provides RF Baud Rates from 650 to 57600 bps
- RF output power default 10 dBm, maximum 19 dBm
- Wireless line of sight (LOS) transmission range of up to 500 meters at an RF Baud Rate of 9600 bps and output power 10 dBm.
- Transparent transmission mode
- Message package is up to 512 bytes
- Provides Baud Rates from 1200 to 115200 bps for both the RS-232 and RS-485 interfaces
- ESD Protection: Contact +/-4 kV
- Isolation: 3000 VDC for DC-to-DC, 2500 Vrms using a photocoupler
- DIN-Rail Mountable
- Operating Temperatures, -25°C ~ +75°C

1.2 Specification

RF Interface	
Radio Frequency	433.1 MHz ~ 434.6 MHz
Channels	0 ~ 15 (default is 4, configured by utility)
Baud Rate	650 ~ 57600 bps
Transmission Power	Default 10 dBm, Max 19 dBm
Antenna	0 dBi Omni directional, RPSMA
Transmission Distance (LoS)	500 m (9600 bps, output power 10 dBm)
Group ID	0 ~ 7
Protocols	Transparent transmit
Repeater	Support repeater mode
Temporary Buffer Size	512 Bytes
COM Port Interface	
RS-232	TxD, RxD and GND
RS-485	D+, D- ; 3000 VDC for DC-to-DC
Baud Rate (bps)	1200 ~ 115200 bps
Data Format	N,8,1 / O,8,1 / E,8,1
LED Indicators	
RF_Tx	Green (RF Transmit)
RF_Rx	Yellow (RF Receive)
PWR	Red (Power)

Isolation	
Intra-module Isolation	2500 Vrms for photocoupler (COM Port)
EMS Protection	
ESD	+/- 4 kV Contact
EFT	+/- 1 kV
Surge	+/- 1 kV
Power	
Input Voltage Range	+10 V _{DC} ~ +30 V _{DC}
Power Consumption	1 W @ 24 V _{DC}
Mechanical	
Dimensions (W x L x H) (not include antenna)	108 mm x 84 mm x 33 mm
Antenna Dimensions (L x Ø)	108 mm x 10 mm
Installation	DIN-Rail
Environment	
Operating Temperature	-25°C ~ +75°C
Storage Temperature	-30°C ~ +80°C
Relative Humidity	10 to 90% RH (Non-condensing)

1.3 Dimensions

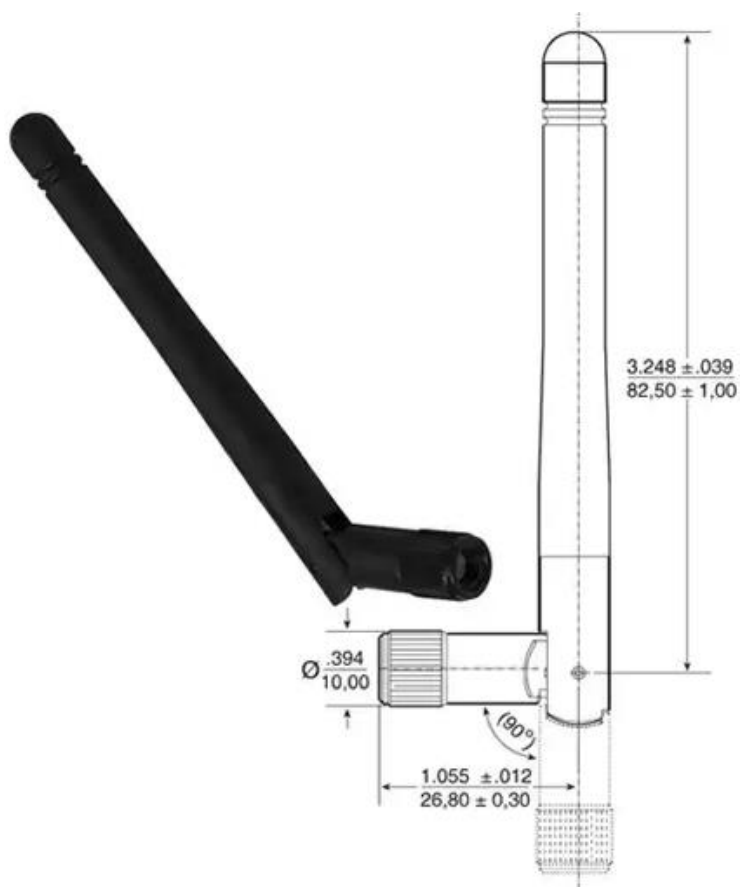
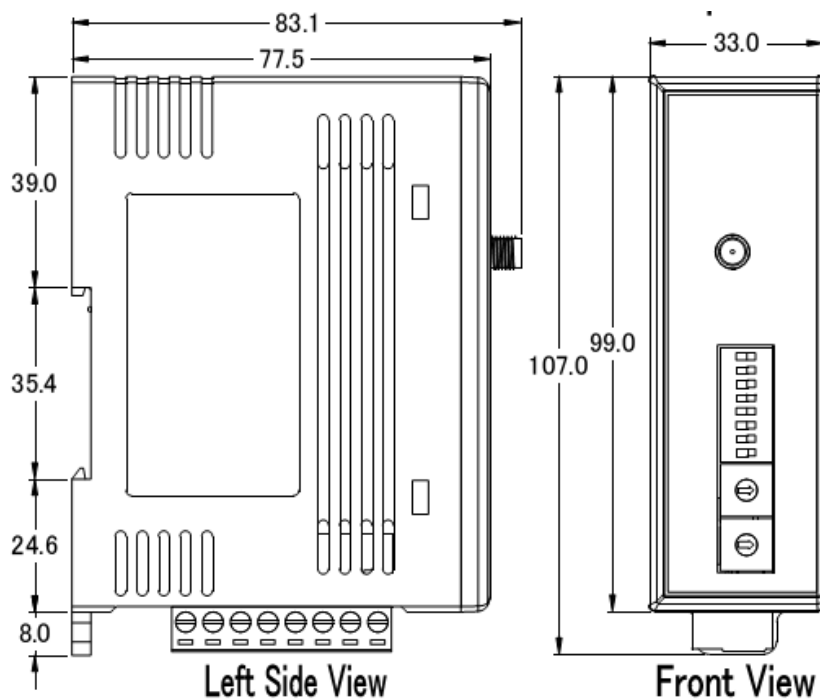

1.4 Appearance

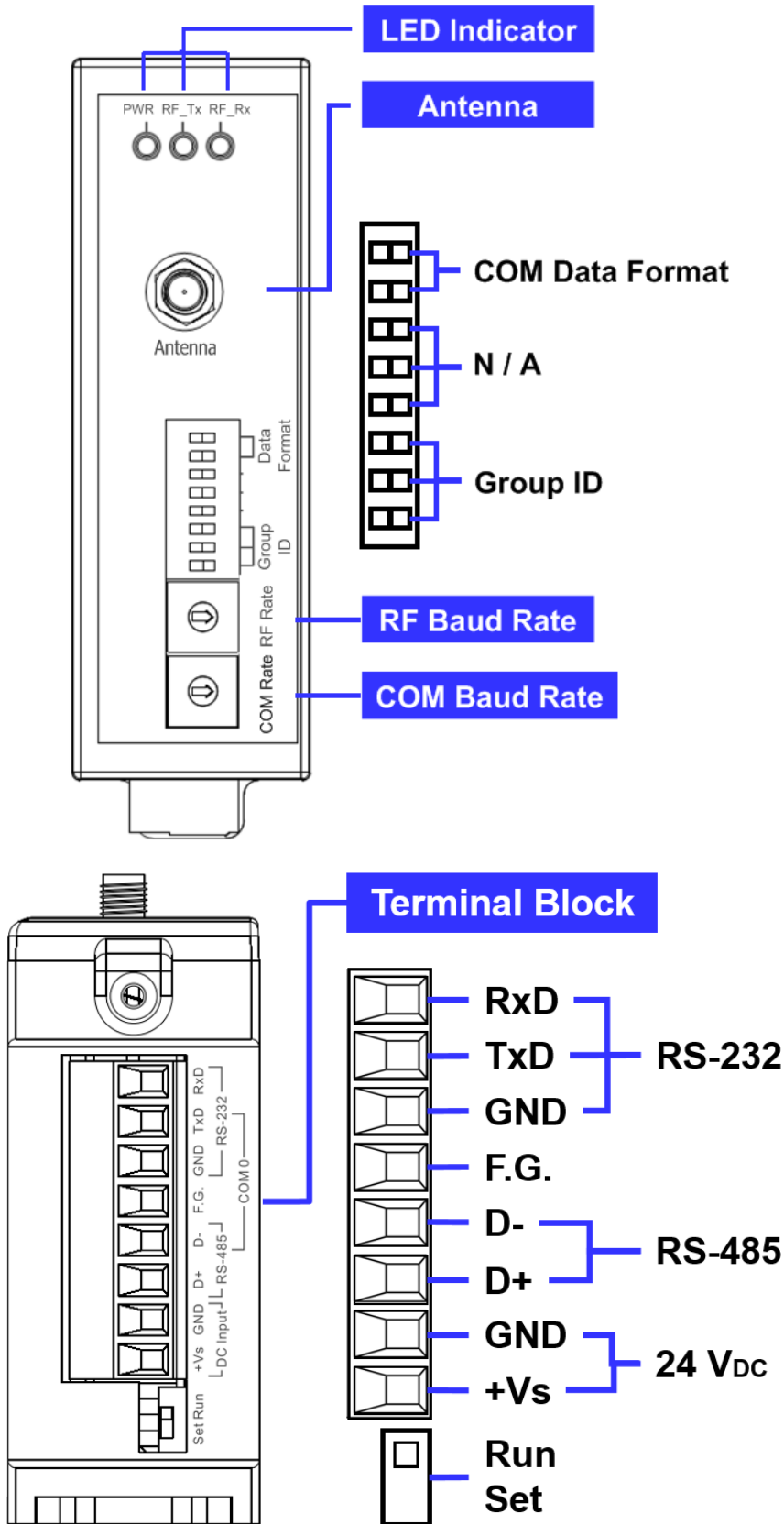

Terminal Block

	Pin	Description
<p>+Vs GND D+ D- F.G. GND TxD RxD DC Input RS-485 RS-232 ----- ----- ----- COM 0</p>	RxD	RS-232
	TxD	
	GND	
	F.G.	Frame Ground
	D-	RS-485
	D+	
	GND	Power:
	+Vs	+10 ~ +30 V _{DC} , 1A

LED Indicator

LED	Behavior	Description
PWR	On	+10 ~ +30 V _{DC} Power On
	Off	Power Off
RF_Tx	On	RF is transmitting data
	Off	RF is no data to transmit
RF_Rx	Always On	RF is receiving data, signal strength high
	100ms Flash	RF is receiving data, signal strength middle
	500ms Flash	RF is receiving data, signal strength low
	Off	RF is no data to receive

2. Configuration

The RFU-433 has the following descriptions about the rotary and dip switches in the hardware setting mode:

COM Baud Rate

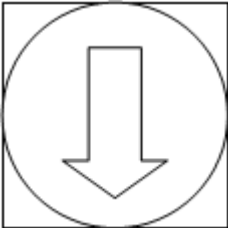





Switch Name	Number	Baud Rate (bps)	Number	Baud Rate (bps)
 COM Rate	0	115200	5	4800
	1	57600	6	2400
	2	38400	7	1200
	3	19200	8 ~ E	Reserved
	4	9600		

RF Baud Rate

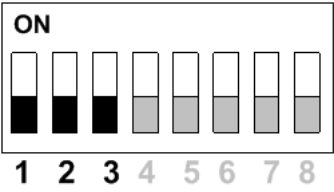
Switch Name	Number	Baud Rate (bps)	Number	Baud Rate (bps)
 RF Baud Rate	0*	Auto set the same with COM Baud Rate	5	4800
			6	2400
	1	57600	7	1200
	2	38400	8	650
	3	19200	9 ~ E	Reserved
	4	9600	F	Firmware version

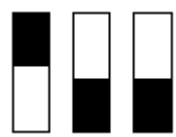
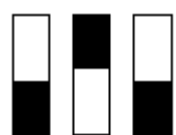

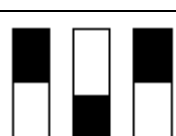
* If COM Baud Rate is 115200 bps, the RF Baud Rate will set to 57600 bps.

Group ID

Switch Name	Switch	Group ID Number
 <p>Group ID</p>		0
		1
		2
		3
		4
		5
		6
		7

* RFU-433 with different Group ID cannot communicate with each other.

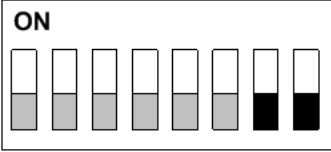
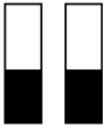
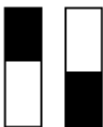
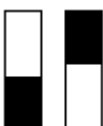
COM Data Format

Switch Name	Switch	Data Format
 <p>COM Data Format</p>		N, 8, 1
		O, 8, 1
		E, 8, 1
		Repeater Mode (1 hub)

* The repeater mode can bypass RF message from one side to another. For example, if the repeater received a message "0x01 0x02 0x03 0x04", then the repeater will transmitted the same message to RF.

Note that, repeater mode only support 1 hub.

Setting Switch

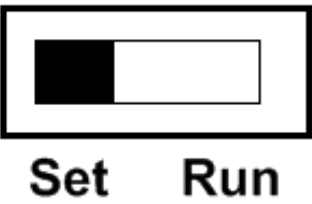
Switch Name	Switch	Description
	Set *	Utility Setting Mode
	Run	Normal Run Mode

* In set mode, user can set the "Channel" , "Output Power" , "Message Duty" and other parameters through the RFU-433 Utility.

3. RFU-433 Utility

When RFU-433 utility connects with RFU-433 in set mode through COM port. The utility will get the RFU-433 firmware version and configuration. User also can change the RF channel and communication frequency to RFU-433 through the utility.

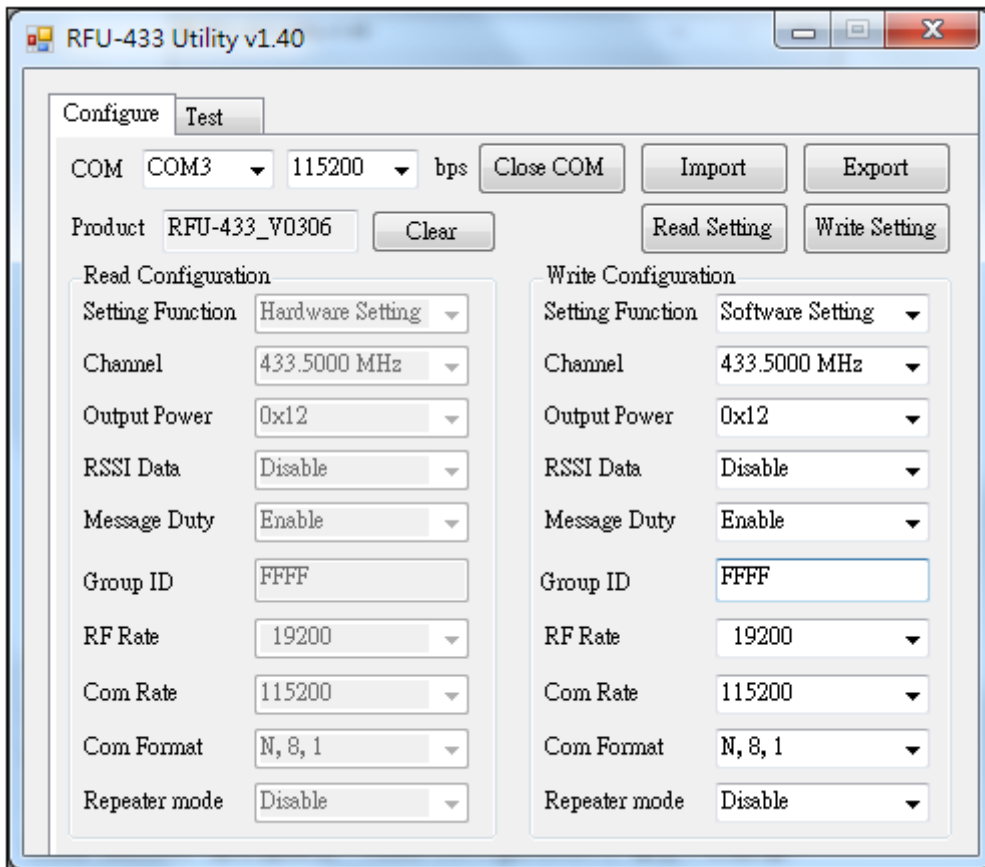

Open COM Button: Open COM port and connect to RFU-433.

Close Button: Close COM port.

Clear Button: Clears the value in the “Read Configuration” field.

Read Setting Button: Read the setting of RFU-433 and display it in the “Read Configuration” field.

Write Setting Button: Write the parameters in the "Write Configuration" field to the RFU-433 and read them back to the "Read Configuration" field for confirmation.

Import Button: Load the RFU-433's configuration file and display it in the "Write Configuration" field.

Export Button: Export the settings of the "Write Configuration" field.

Product: Here will show the module name and firmware version.

Setting Function: It includes "Hardware Setting" and "Software Setting". For "Hardware Setting", the "Channel" is 433.5000 MHz, the "Output Power" is 10 dBm and the "Message Duty" is enabled. About "Group ID", "RF Rate", "Com Rate", "Com Format" and "Repeater mode" are based on the rotary and dip switches on the RFU-433 module.

Channel: Wireless channel selection range from 433.1000 MHz ~ 434.6000 MHz, total 16 channels.

Output Power: The RF output power is from 0x00 ~ 0x7F. Default is 10 dBm and 0x7F is the max (19 dBm).

RSSI Data: After enabling this function, RFU-433 will add the RSSI value of the sending side and the RSSI value of the receiving side to the back of the received wireless packet, and then transmit it to RS-232 / RS-485. For example, when RFU-433 receives a wireless packet of "0x01 0x02 0x03 0x04", it will combine two bytes of the RSSI value of the sending side (e.g. 0x63) and local side (e.g. 0x75) into that wireless packet, which will become "0x01 0x02 0x03 0x04 0x63 0x75", and then send out the packet from the COM port. The range of the RSSI value is from 0x00 to 0xFF, of which 0xFF is

the value of the best communication signal.

Message Duty: Message duty is the minimum time interval for RF message. The “next package” time interval is calculated as 10 times of the “current package” transmission time. For example, if a 20 Bytes data is transmitted at 9600 bps, the transmission time is about 20 ms, so the next time RFU-433 can transmit a wireless packet is after 200 ms, that is, the signal duty ratio is 10%, which is the CE specification for wireless transmission in 433 MHz band.

Group ID: Group ID support ranges from 0x0000 to 0xFFFF, where 0x0000 to 0x0007 is equivalent to Group ID 0 to 7 provided on the switch.

RF Rate: When “Software Setting” is selected, the RF Rate rotary switch on the module will be disabled and the drop-down menu will be set instead.

Com Rate: When “Software Setting” is selected, the Com Rate rotary switch on the module will be disabled and the drop-down menu will be set instead.

Com Format: When “Software Setting” is selected, the Com Format dip switch on the module will be disabled and the drop-down menu will be set instead.

Repeater mode: When “Software Setting” is selected, the Repeater mode dip switch on the module will be disabled and the drop-down menu will be set instead.

- **Group ID, RF Rate, Com Rate, Com Format, Repeater mode are new settings in RFU-433 Firmware v3.06.**

4. Application Example

1 - 1 Transfer



PC controls RS-485 modules 1 ~ 3 through RFU-433.

1 - Multi Transfer



PC controls RS-485 modules 1 ~ 3 through a RFU-433 and modules 4 ~ 6 through another RFU-433

Repeater Mode

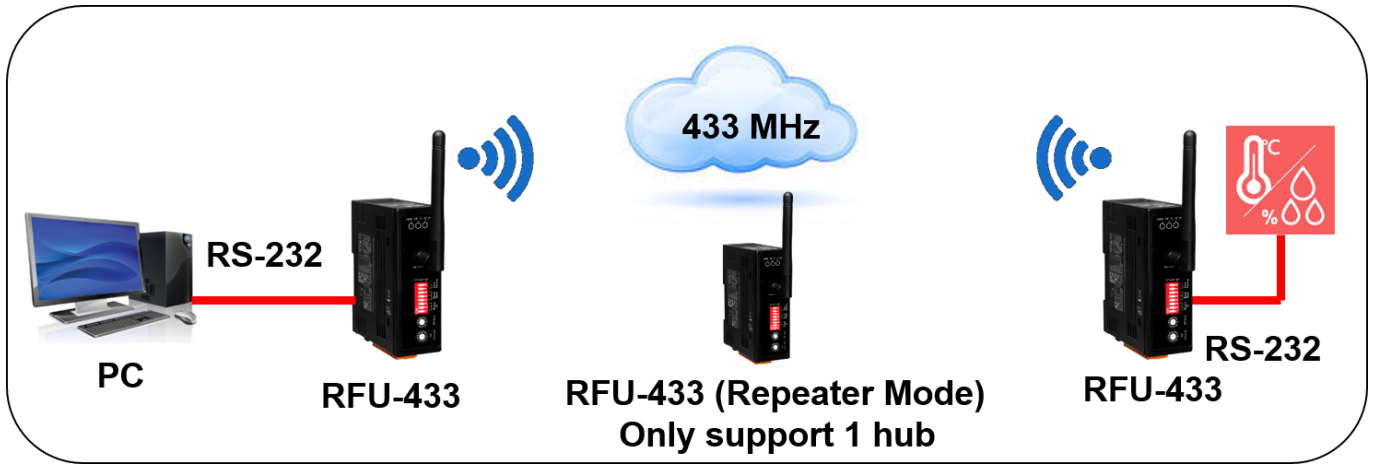



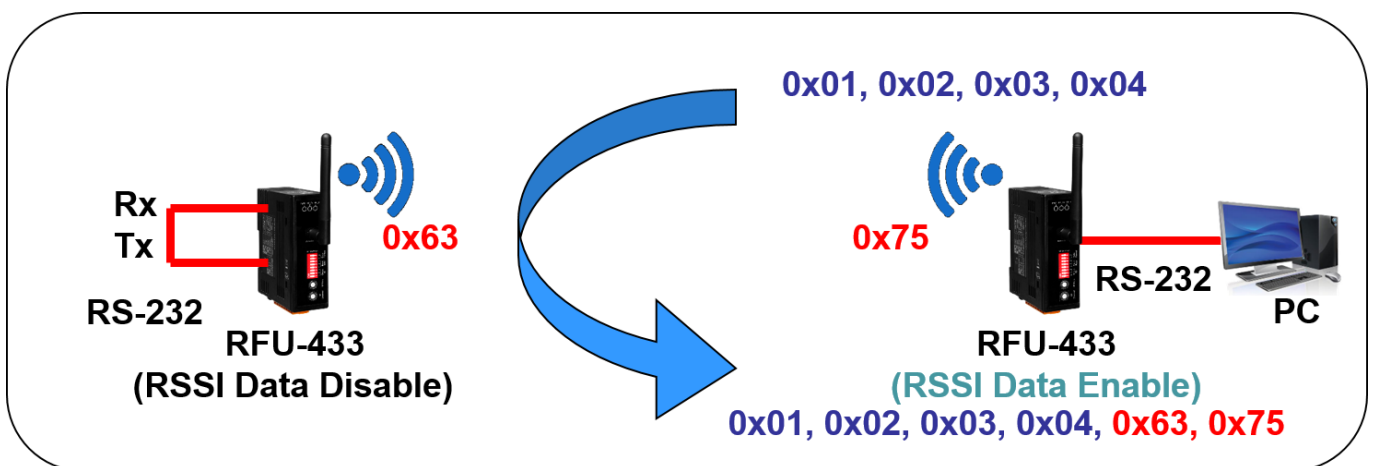

PC cannot monitor the thermometer and hygrometer directly because the distance is too far. But the repeater can bypass the RF message one side to another and let PC can monitor the thermometer and hygrometer.

RSSI Test



User can enable "RSSI Data" to check the RSSI value.

A. RSSI Data and Signal Strength Description

RSSI Data	dBm	Icon	Strength Description
0 ~ 89	< -85		Unconnectable or invisible
90 ~ 119	-85 ~ -71		The vast majority of terminals are not connectable
120 ~ 159	-71 ~ -53		Connectable, unstable
160 ~ 199	-53 ~ -35		Normal use
200 ~ 255	> -35		Strong signal, best experience

- RSSI Data corresponds to the dBm conversion formula:

$$\text{dBm} = -126 + (\text{RSSI Data} * 0.457)$$